

H-FLO Series

SEAL-LESS ECCENTRIC DISC PUMP

*** NEW ***
Flow Rates
Up To
70 m³/h



Where Innovation Flows



Introducing the Seal-Less Eccentric Disc Transfer Solution for Hygienic Applications Requiring High Flow Rates

Mouvex® H-FLO Series Seal-Less Eccentric Disc Pumps have been designed for use in a wide range of pumping applications in the food, cosmetic and pharmaceutical industries, all of which require extremely hygienic operations. The H-FLO pump delivers high suction vacuum and high discharge pressure that allow it to self-prime and fully strip lines, a critical consideration when maximizing product recovery.



Mouvex H-FLO Series | Eccentric Disc Pump



SEAL-LESS DESIGN

The unique seal-less design features a triple stainless steel bellows that ensures durability, safety and product containment. The H-FLO Series provides high suction vacuum and high discharge pressure, which allows it to self-prime and fully strip lines, maximizing product recovery.

RUN DRY CAPABILITY

The H-FLO Series can run dry for up to five minutes, and the self-compensating eccentric disc principle provides consistent flow rates over a long period of time. The flow rate is extremely accurate even at low speeds.

DEPENDABLE

Fewer moving parts results in reduced maintenance and downtime.

ADVANTAGES

- Provides consistent and efficient flow with a wide range of viscosities
- Flow rate up to 70 m³/h (308.2 gpm), 10 bar (145 psi)
- Eccentric disc design allows for consistent flow and improved energy savings
- Extremely gentle, pulse-free flow to protect shear-sensitive products
- Reduced maintenance with no mechanical seals or timing gears
- Easy to install
- Clean in place (CIP) and sterilize in place (SIP) for the ultimate in convenience and cleanliness

OPTIONS

- SMS
- DIN 11851
- DIN 11864 BF-A Aseptic fl
- Tri-Clamp® ASME-BPE
- Heating Jacket



OPERATION

- **Principle:** Eccentric disc, positive displacement
- **Installation:** Can be base mounted

CONSTRUCTION

- All stainless steel construction
- Shaft sealed by triple stainless steel bellows
- Ra 0.8 µm (32 µ inch) wetted surfaces

CERTIFICATIONS



Mouvex H-FLO Series | General Information

FEATURES & BENEFITS:

- Seal-less design eliminates leakage
- Ability to strip and drain transfer piping/tubing
- Line-stripping capabilities
- Self-priming
- Strong suction and discharge pressure
- Ability to handle shear-sensitive products
- Consistent flow rate independent of pressure
- Low linear speed
- Precise dosing
- Accurate volume metering with high turn down
- Dry-run capable
- Maintains consistent performance over time
- Effective with both high- and low-viscosity fluids
- Full drainability
- Clean-In-Place (CIP)/Sanitize-In-Place (SIP)
- Easy integration

APPLICATIONS:

Suitable for most sanitary applications, including food and beverage, pharmaceutical, and cosmetic processes, in particular those that require consistent non-pulsing flow and gentle fluid handling (low shear rate) such as:

In the food industry:

- Sauce, chocolate, glucose...

In the beverage industry:

- Concentrate, glucose, fruit juice, flavor, alcohol...

In the dairy industry:

- Yogurt, ferment, dessert, yolk...

In the cosmetic and pharmaceutical industry:

- Ointment, syrup, cream, suppository, shampoo...

MOUVEX TECHNOLOGY

Eccentric disc pumps consist of a cylinder and pumping element mounted on an eccentric shaft. As the eccentric shaft is rotated, the pumping element forms chambers within the cylinder, which increase in size at the intake port, drawing fluid into the pumping chamber. The fluid is transported to the discharge port where the pumping chamber size is decreased. This action squeezes the fluid out into the discharge piping.

MOUVEX PRINCIPLE

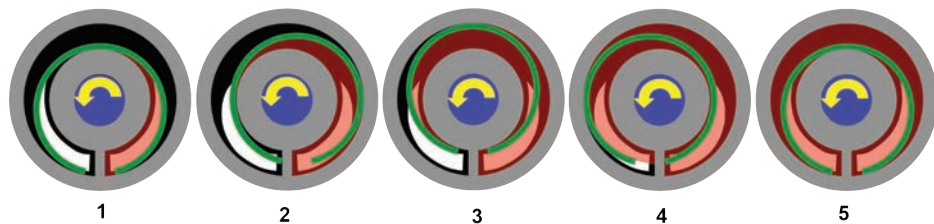

Mouvex H-FLO Series | Performance Data

PUMP MODEL	MAXIMUM FLOW RATE		MAXIMUM SPEED	MAXIMUM OUTPUT PRESSURE		MAXIMUM TEMPERATURE	
	m ³ /h	gpm	rpm	bar	psi	°C	°F
H-FLO 65-S	70	308.2	350	7	101	100	212
H-FLO 65-HP	54	237.7	350	10	145	100	212
H-FLO 50	55	242.2	400	10	145	100	212
H-FLO 40	43	189.3	460	10	145	100	212
H-FLO 25	27.5	121.1	525	10	145	100	212

Mouvex H-FLO Series | Dimensions

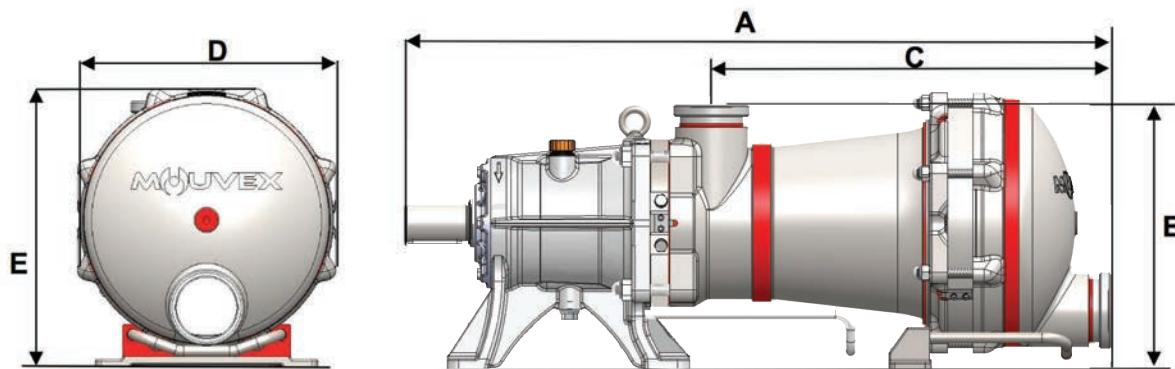

PUMP MODEL	DN mm (in)	A mm (in)	B mm (in)	C mm (in)	D mm (in)	E mm (in)	Weight kg (lbs)
H-FLO 65-S	100 (3.94)	1177 (46.34)	434 (17.03)	672.5 (26.48)	448 (17.64)	464 (18.27)	321 (708)
H-FLO 65-HP	100 (3.94)	1177 (46.34)	434 (17.03)	672.5 (26.48)	448 (17.64)	464 (18.27)	315 (695)
H-FLO 50	100 (3.94)	1066.5 (41.99)	400 (15.75)	623 (24.53)	410 (16.14)	425 (16.73)	225 (497)
H-FLO 40	76 (3)	1023 (40.28)	386.5 (15.22)	591 (23.67)	354 (13.94)	372 (14.65)	175 (386)
H-FLO 25	76 (3)	872 (34.33)	346 (13.59)	518.5 (20.41)	304 (11.97)	327 (12.87)	122 (269)

(With SMS Connections)

MX-10510-F-03-A4

Copyright 2021 PSG®, a Dover company

Authorized PSG® Partner:

Where Innovation Flows



PSG
 ZI la Plaine des Isles • 2 rue des Caillottes
 F-89000 Auxerre, France
 P: +33 (0) 3 86 49 86 30
 contact.mouvex@psgdover.com

psgdover.com/mouvex